

ELITE RECOMMEND THE USE OF A FULL SYNTHETIC 75W90 GRADE OIL, FILL TO THE OIL LEVEL ON REAR OF THE GEARBOX. GEARS ARE R, N, 1, 2, 3, 4, 5 & 6 WHEN CHANGING UP THE BOX THE NEUTRAL/REVERSE LOCKOUT PLUNGER IS NOT IN USE. ON DOWN SHIFTS THE PLUNGER IS LIFTED TO GO FROM 1st TO NEUTRAL AND ALSO FROM NEUTRAL TO REVERSE.

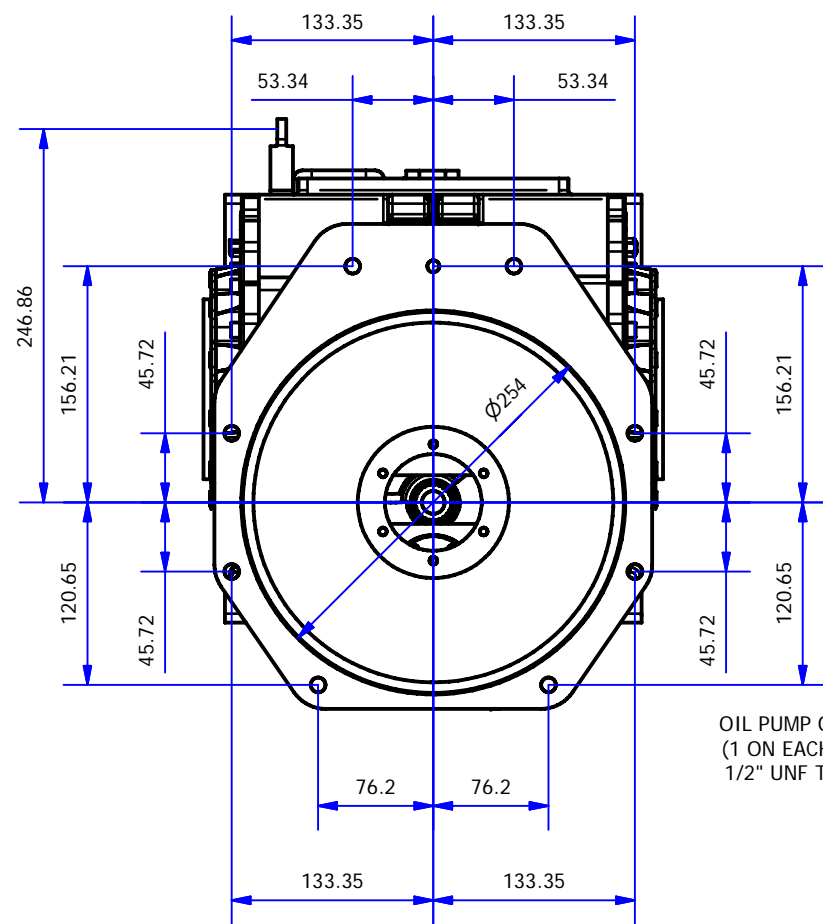

OIL PUMP OUTLET
(1 ON EACH SIDE)
1/2" UNF THREAD

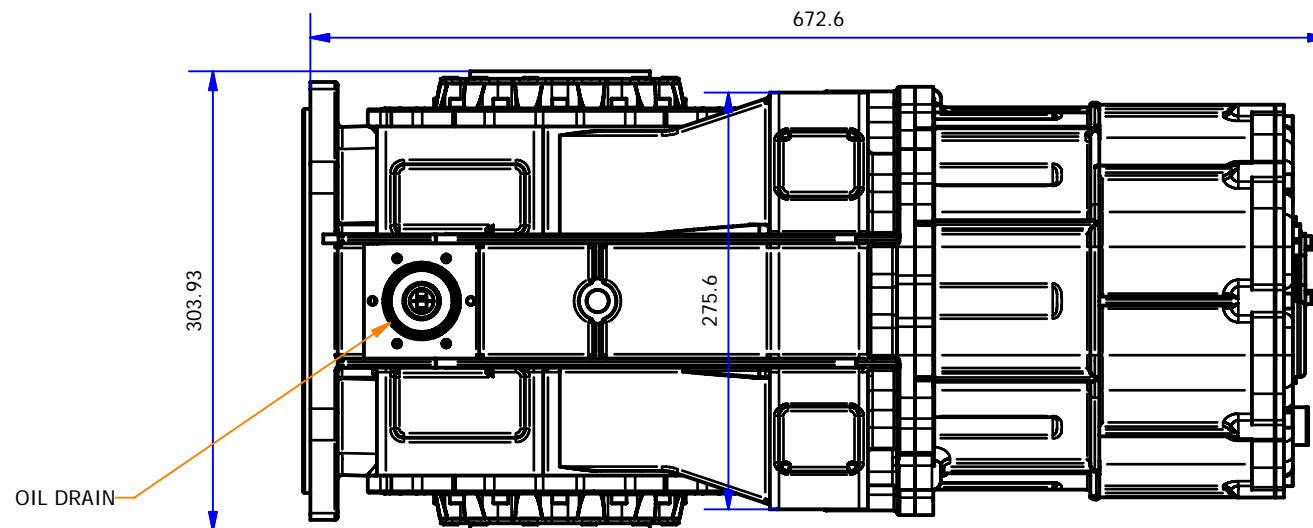
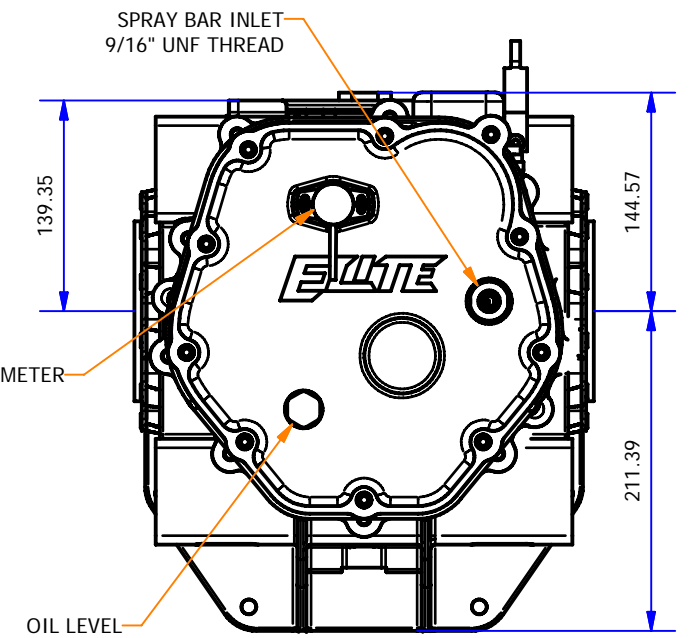
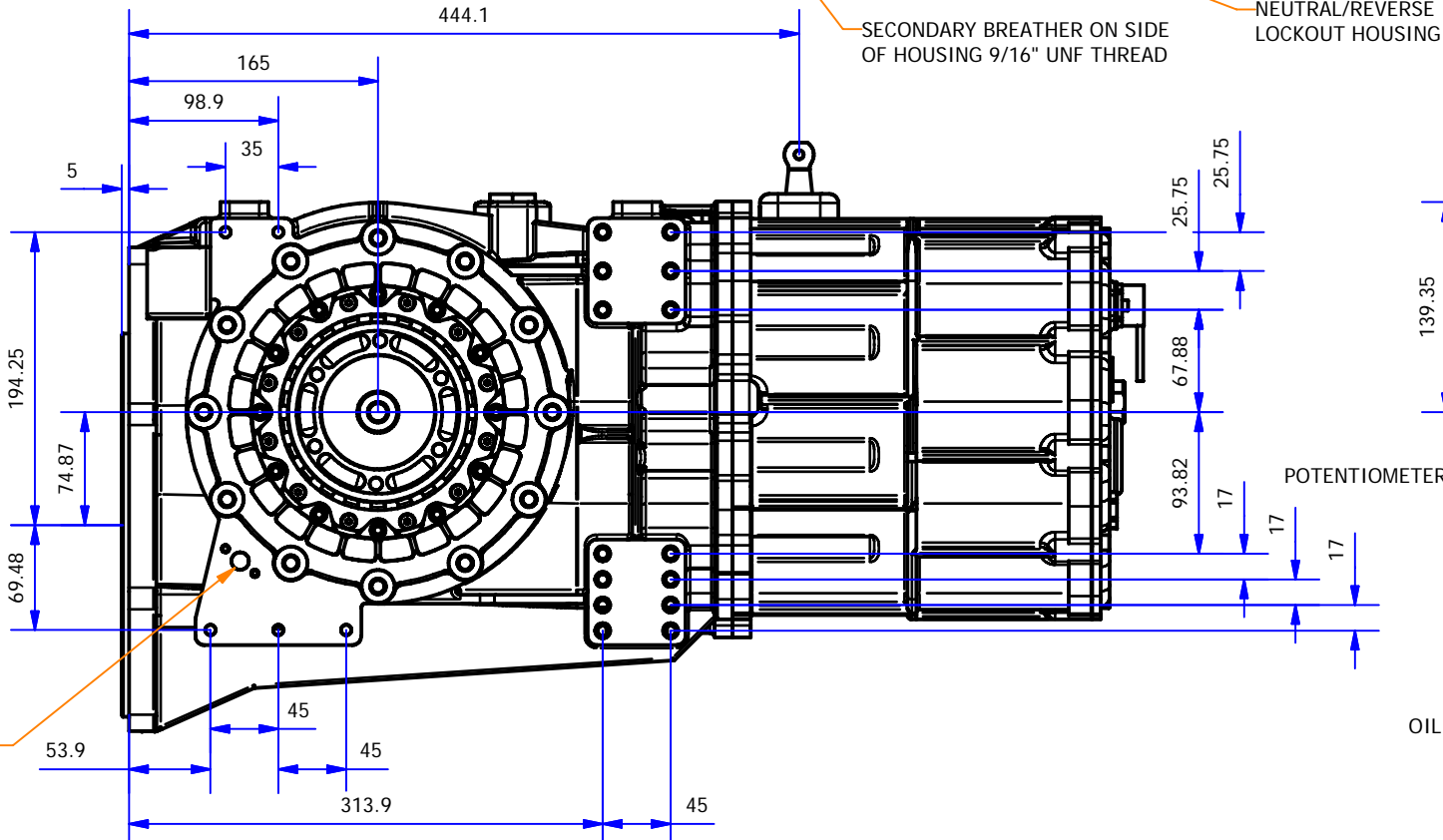
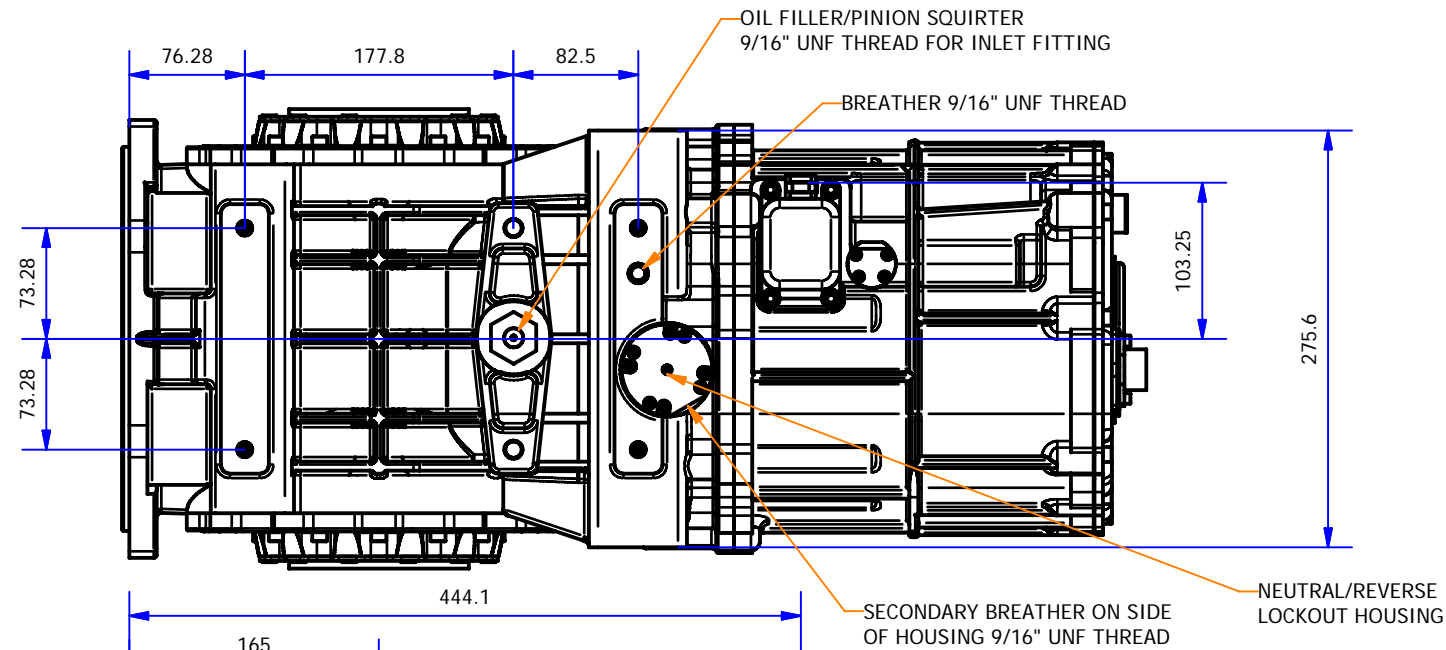

Gearworks,
Salem St.,
Etruria,
Stoke On Trent, ST1 5PR.
Tel 01782 280136,
Fax 01782 269913,
Email contact@eliteracingtransmissions.com

TITLE
TXL 300-6S ASSEMBLY

DRG. No. ERT90308

Issue