

REVERSE LOCK OUT PULLER  
PULL UPWARDS TO ENGAGE REVERSE GEAR

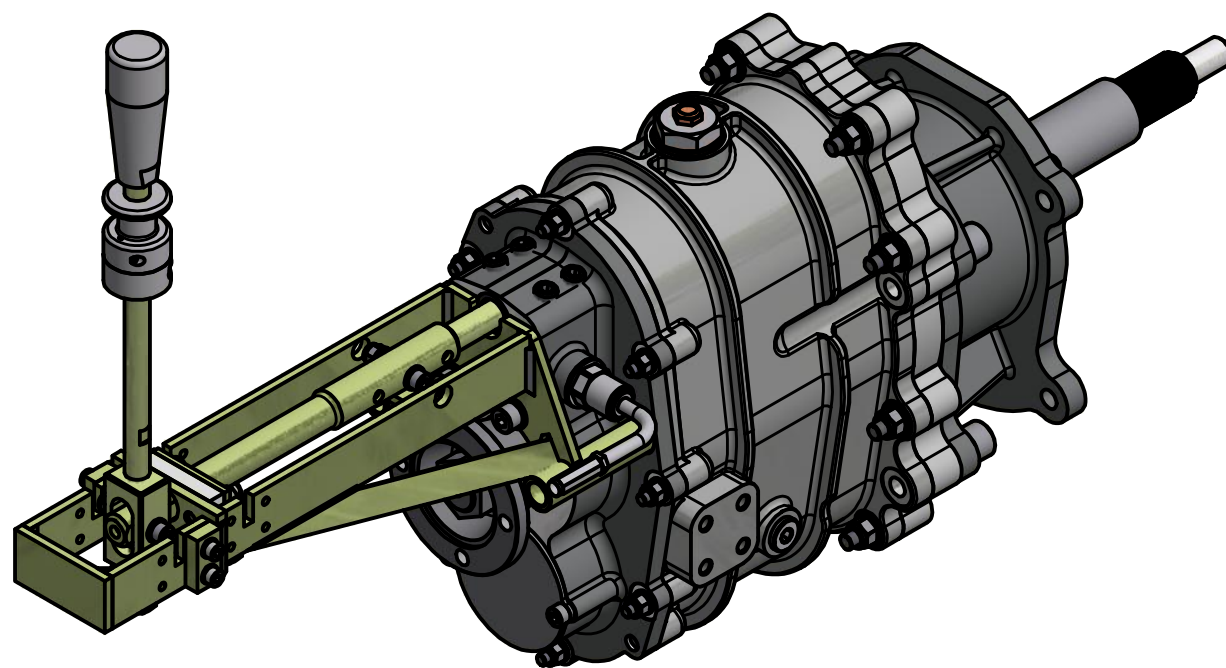
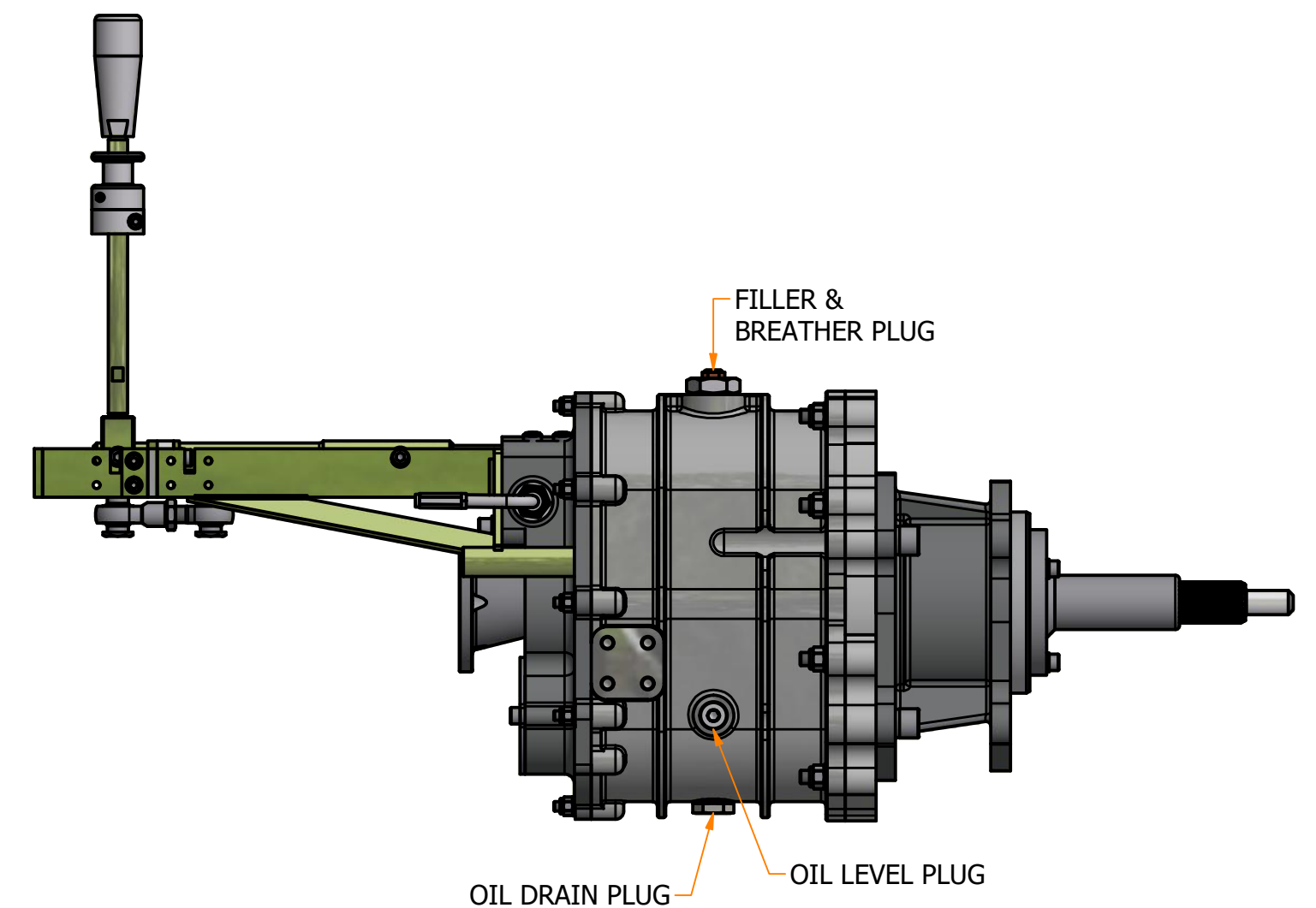
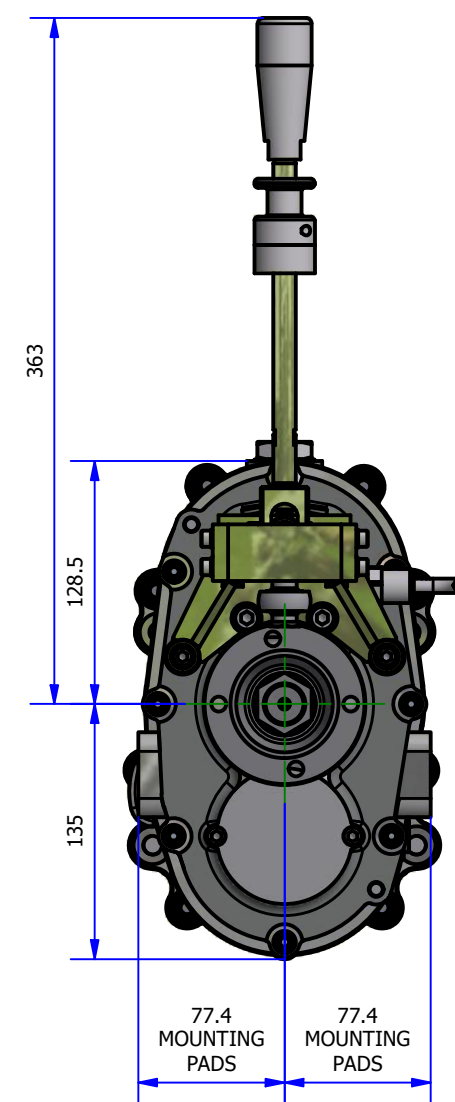
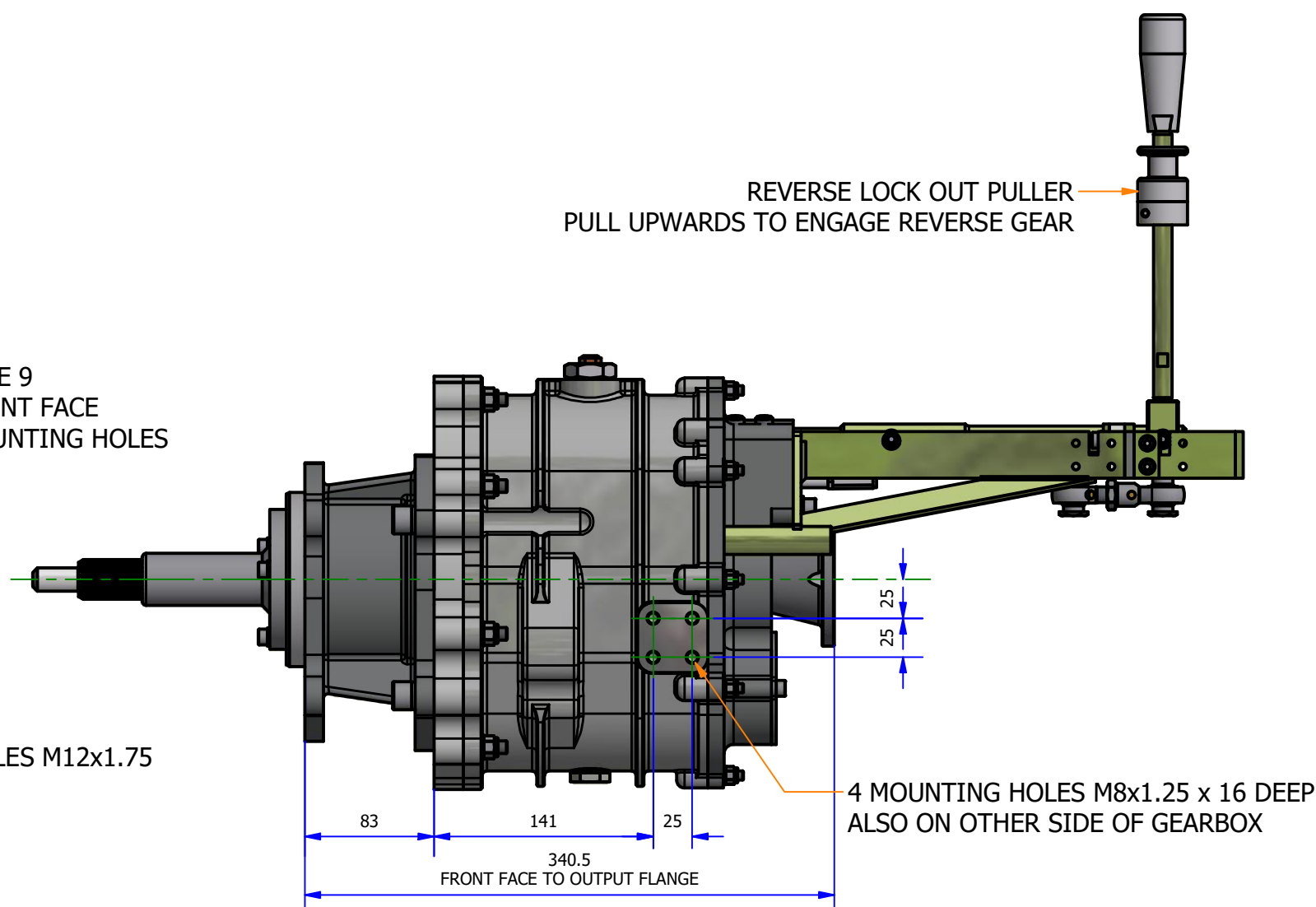

### **IL-150 EVO-2 GEARBOX INFORMATION**

- GEARBOX SUPPLIED WITOUT OIL
- OIL CAPACITY = 1.00 LITER
- USE A FULLY SYNTHETIC 75W90 GRADE OIL
- ELITE RACING TRANSMISSIONS RECOMMEND USING RED LINE LIGHTWEIGHT SHOCKPROOF OIL

### GEARSTICK SELECTION PATTERN

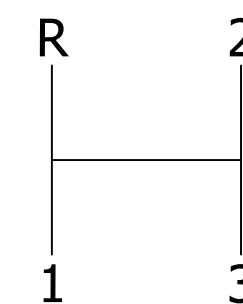

TITLE  
NATIONAL HOT ROD FULL GEARBOX  
ASSEMBLY - IL-150 EVO-2

DRG. No. ERT914633

Issue  
0