

REVERSE LOCK OUT PULLER  
PULL UPWARDS TO ENGAGE REVERSE GEAR

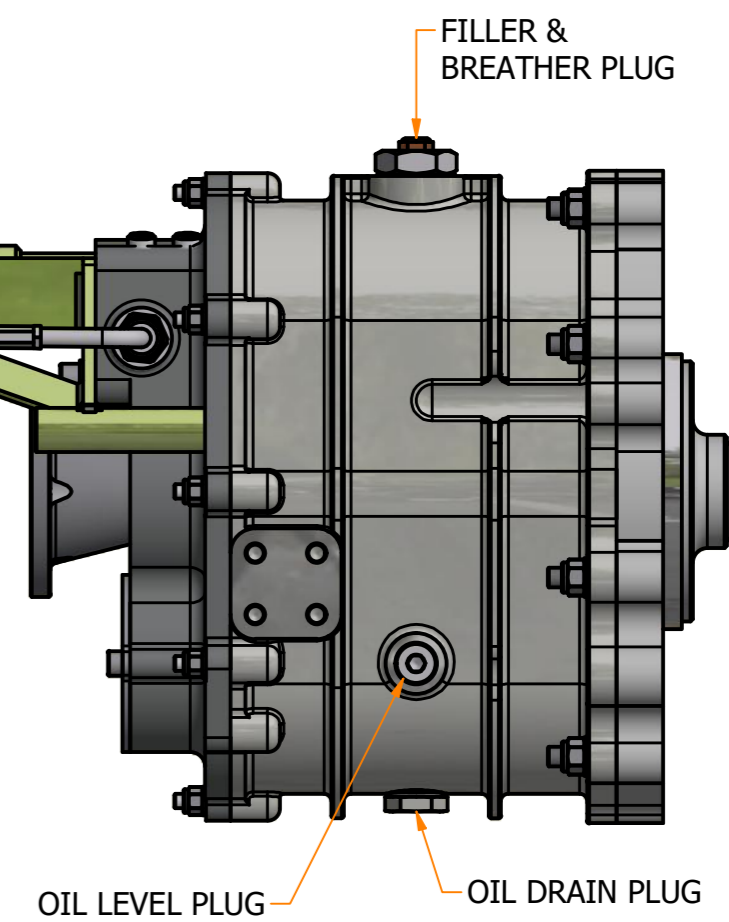

4 MOUNTING HOLES M8x1.25 x 16 DEEP  
ALSO ON OTHER SIDE OF GEARBOX

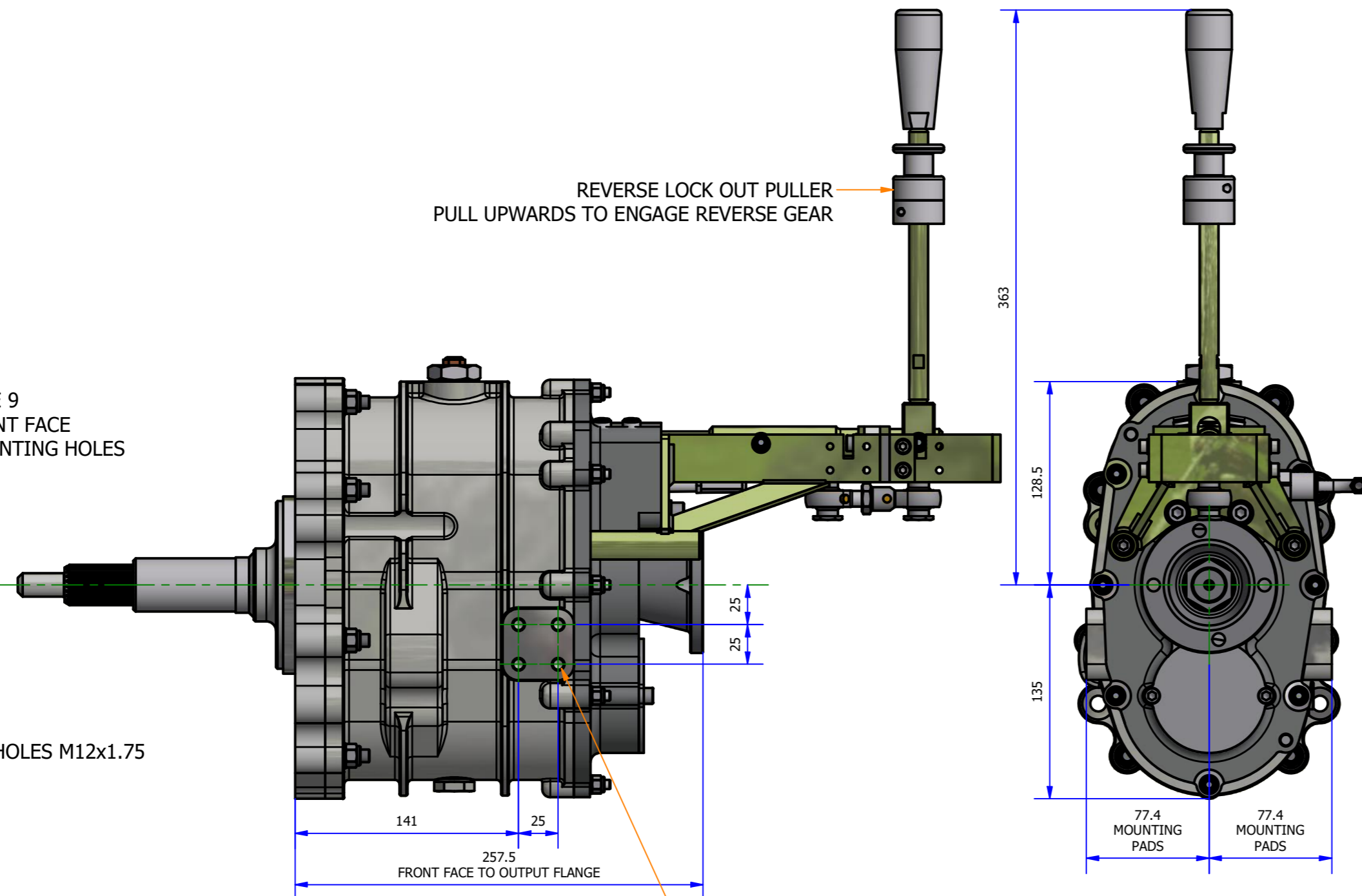
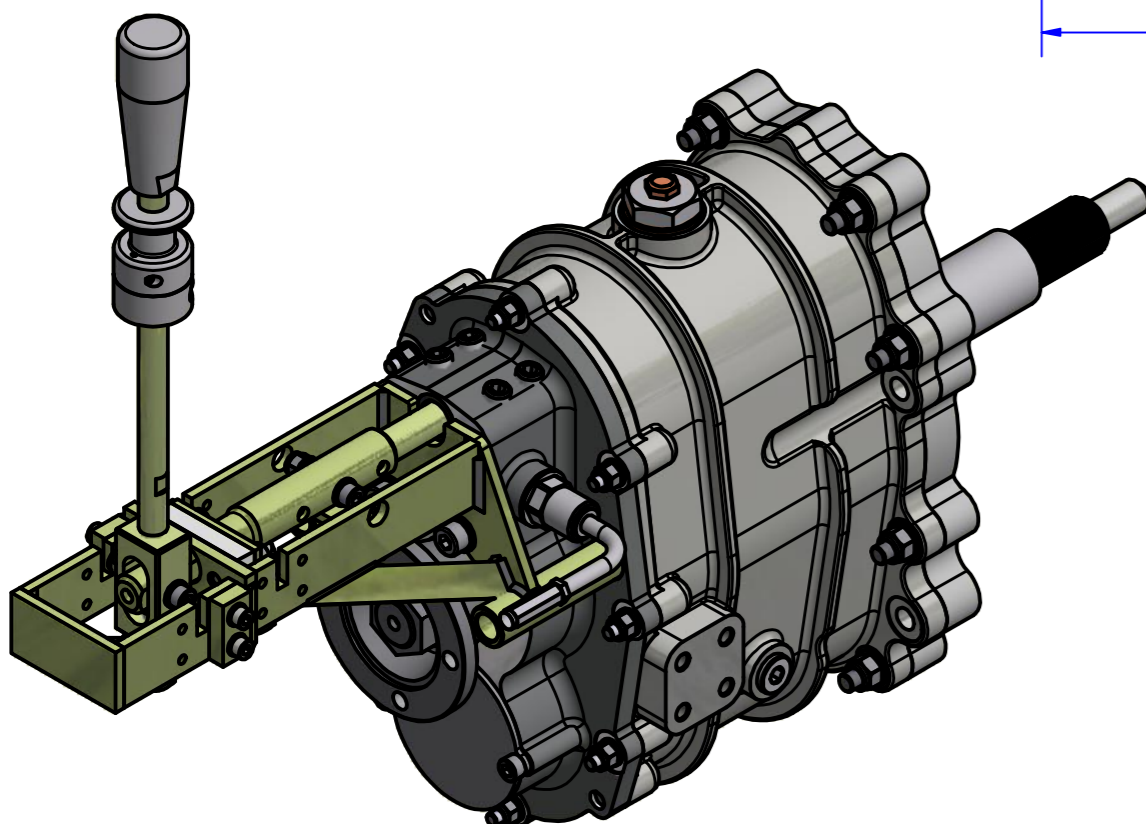

### IL-150 EVO-2 GEARBOX INFORMATION

- GEARBOX SUPPLIED WITHOUT OIL
- OIL CAPACITY = 1.00 LITER
- USE A FULLY SYNTHETIC 75W90 GRADE OIL
- ELITE RACING TRANSMISSIONS RECOMMEND USING RED LINE LIGHTWEIGHT SHOCKPROOF OIL

GEARSTICK  
SELECTION PATTERN

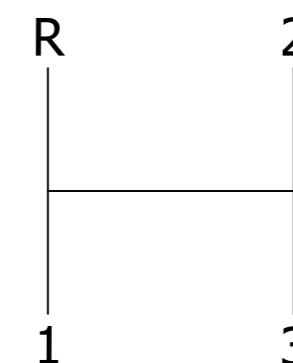

TITLE  
F2 STOCK CAR FULL GEARBOX ASSEMBLY -  
IL-150 EVO-2

DRG. No. ERT914615

Issue  
0